

Communication Assemblies P/N 515-023 and 515-024 (New Design)

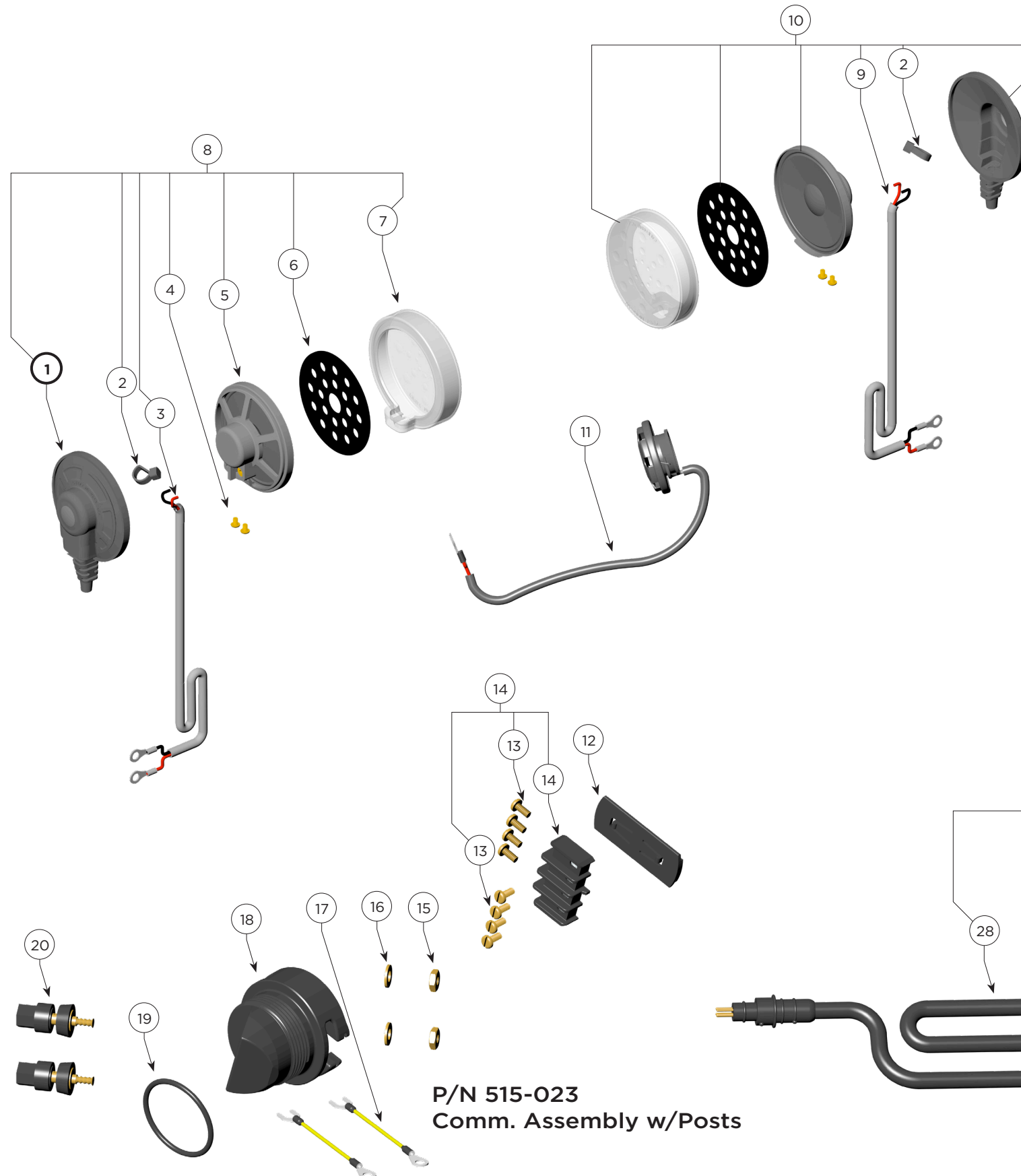

Location #	Part #	Description
1		For Earphone Cover Set Order 510-842
2	520-038	Tie-Wrap
3	515-102	Communication Wire 9"
4	530-098	Screw
5	515-090	Earphone, Speaker Only
6	520-015	Protector, Earphone
7		For Earphone Cover Set Order 510-842
8	515-018	Earphone, Right 9"
9	515-101	Communication Wire 15.5"
10	515-019	Earphone, Left 15.5"
11	515-029	Microphone Assembly
12	520-515	Strip Retainer Plate
13	330-030	Screw
14	515-125	Strip Assembly with Screws
15	530-308	Hex Nut
16	530-525	Washer
17	515-055	Wiring Harness, Posts
18	550-181	Comm. Module for Posts

Location #	Part #	Description
19	510-029	O-ring
20	315-020	Comm. Posts
21	550-040	Nut
22	550-183	Comm. Module for MWP
23	515-049	Single Wire Terminal
24	510-481	O-ring
25	555-175	Packing Gland
26	520-113	Ferrule Set
27	555-178	Packing Nut
28	515-045	W.P. Connector (Male) 4 Pin
29	505-047	W.P. Connector Assembly

Complete Assemblies		
	515-023	Comm. Assembly w/Posts
	515-024	Comm. Assembly w/MWP

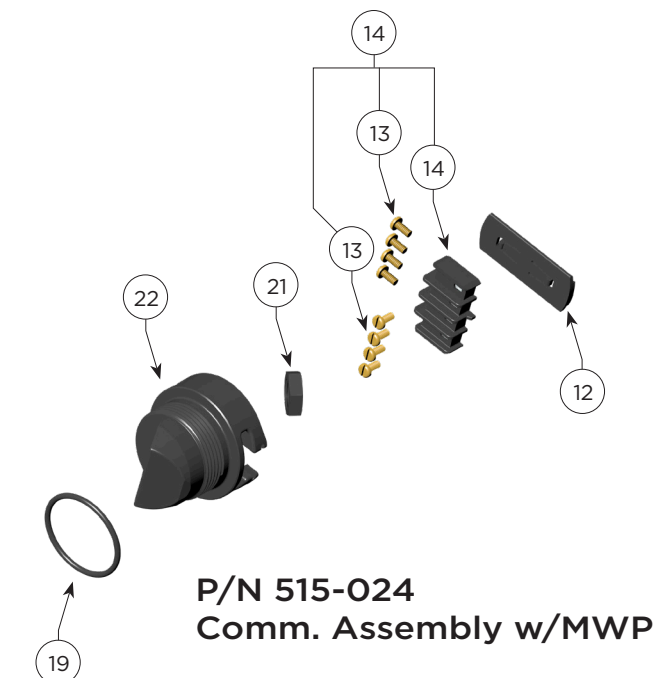

**P/N 515-024
Comm. Assembly w/MWP**



Kirby Morgan Dive Systems, Inc.® 1430 Jason Way, Santa Maria, CA 93455
 Phone: (805) 928-7772 Fax: (805) 928-0342
www.KirbyMorgan.com e-mail: kmdsi@KirbyMorgan.com