



Kirby Morgan Dive Systems, Inc.®

1430 Jason Way Santa Maria, California 93455

Phone: 805/928-7772 Fax: 805/928-0342

www.KirbyMorgan.com email: kmdsi@KirbyMorgan.com

Part #525-757 SuperFlow® 450 Regulator Parts Upgrade Kit

Part Number	Description	Qty
205-020	Inlet valve Assembly	1
210-055	O-ring	2
505-088	Adjustment Knob/Packing Nut Assembly	1
550-549	Balance Spacer	1
550-643	Transfer Pin	1
540-531	Lock Clip	1

NOTE: The upgrade kit assembly procedures are illustrated with the Regulator Body being shown removed from the helmet. This is done only to emphasize and clarify the procedure. The Regulator Body can remain in place (attached to the helmet) when completing the upgrade. **THERE IS NO NEED TO REMOVE THE REGULATOR BODY FROM THE HELMET** to complete the following upgrade.

⚠ CAUTION

Use only KMDSI original replacement parts. The use of other manufacturers' parts will interfere with the performance characteristics of your life support equipment and may jeopardize your safety. Additionally, any substitutions will void any warranties offered by KMDSI. When ordering spares, always insist on Kirby Morgan Genuine Parts.

Tools Required:

Torque Screwdriver

Flat blade screwdriver attachment ¼"

Torque wrench

Open end attachments ⅞", 1¼", 1", 1½"

Open end wrench ⅞"

Christo-Lube® or equivalent.

Adjustment Flex Knob Removal

1. Remove the Bent Tube Assembly from the helmet, per "1.3.1 Removal of the Bent Tube Assembly" on page BNT-4.
2. Using a ⅞" wrench, remove the Bent Tube Adapter and O-ring.

Kirby Morgan Dive Systems, Inc.®

1430 Jason Way Santa Maria, California 93455

Phone: 805/928-7772 Fax: 805/928-0342

www.KirbyMorgan.com email: kmdsi@KirbyMorgan.com



3. Remove the Screws and Washers on either side of the Regulator Cover and unscrew the Cover Retaining Ring.

4. Remove the Regulator Cover and Diaphragm. Inspect the Diaphragm for holes or tears. If it is torn or punctured it must be replaced. Inspect the interior of the regulator for foreign matter and clean if necessary.

5. Carefully insert the tip of a flat blade screwdriver into the slot at the top of the Lock Clip to free it from its locking position and slide the clip away from the regulator Main Tube.

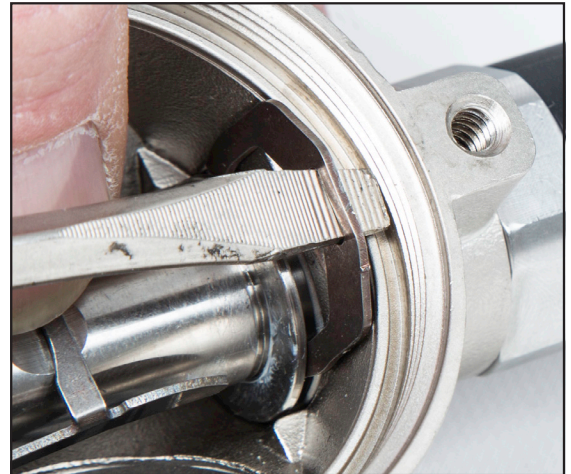

6. Using the 1" open end wrench, loosen the Packing Nut about one turn. Next, while fully depressing the Lever Arm, grasp the Flex Knob and pull it straight out from the Regulator Body. This will remove all of the main components of the regulator valve mechanism as a single, easy to handle unit.

NOTE: If the assembly does not break loose, lightly tap on the threaded end of the Main Tube with the plastic handle of a screwdriver or plastic face hammer to avoid damaging the threads.



Kirby Morgan Dive Systems, Inc.®

1430 Jason Way Santa Maria, California 93455

Phone: 805/928-7772 Fax: 805/928-0342

www.KirbyMorgan.com email: kmdsi@KirbyMorgan.com



7. Unscrew the Flex Knob Assembly from the Main Tube.

8. Remove the Bearing Clip, then remove the lever by gently pulling one leg out from the slot on the Main Tube, followed by the second leg.
9. Slide the Balance Spacer, Spring, and Inlet Valve Assembly out from the Main Tube. Inspect the Main Tube O-ring, Lever Arm, Bearing Clip and Inlet Valve Assembly for signs of wear or damage and replace if necessary.

Upgrade reassembly

⚠ CAUTION

Install the O-rings onto the Balance Spacer prior to beginning reassembly. Be sure that the O-rings on the Balance Spacer have been properly lubricated with one of the lubricants noted. Do not over lubricate the O-rings. Excess lubrication could possibly collect at the end of this part and block the critical air balancing hole.

1. Spread the arms of the Lever Arm just enough to install it onto the Main Tube.

OBSERVATION: Study the features of the Inlet Valve Assembly. There are four “wings” towards one end of the assembly and a bore that creates the balance chamber on the opposite end.

Kirby Morgan Dive Systems, Inc.®

1430 Jason Way Santa Maria, California 93455

Phone: 805/928-7772 Fax: 805/928-0342

www.KirbyMorgan.com email: kmdsi@KirbyMorgan.com



NOTE: The wings that align with the Lever Arm are the two that have an additional wall for the Lever Arm to bear on. The Inlet Valve Assembly should be inserted into the Main Tube with these walls toward the bottom of the regulator tube.

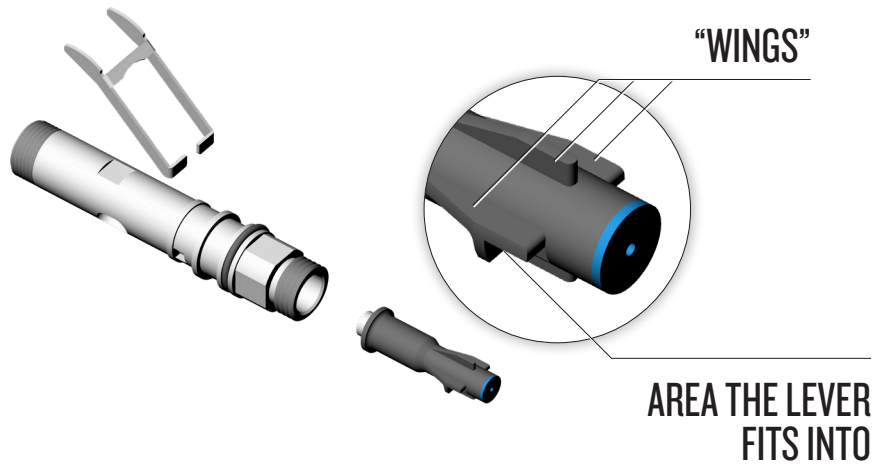

2. Insert the Balance Spacer with the two O-rings installed. Insert the first O-ring into the open end of the inlet valve stainless steel tube and stop at the second O-ring. Next, align and insert the Inlet Valve into the Main Tube, as noted above. If this is done properly, the lever should lift up. If it does not, the Inlet Valve has not been aligned correctly.

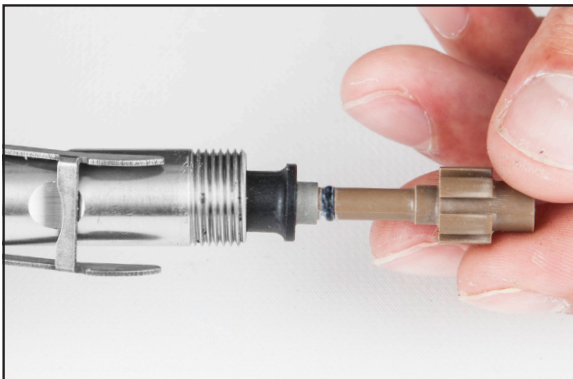

3. While holding the Inlet Valve in position, pinch each arm of the Lever Arm and slowly remove the Balance Spacer and O-rings. The Inlet Valve should remain in place. If it comes out, repeat the process until the Inlet Valve stays in place.

NOTE: BROWN indicates the current Balance Spacer.
DARK GREY indicates the earlier Balance Spacer.
Both are fit for use. Difference in color ONLY.

4. Install the Spring and Balance Spacer with O-ring into the Main Tube. Make sure the Balance Spacer is properly aligned inside the Main Tube by pushing in on the end of the Balance Spacer and slightly turning it with your finger tip to see that it moves inward (i.e., it engages the hole in the Inlet Valve).

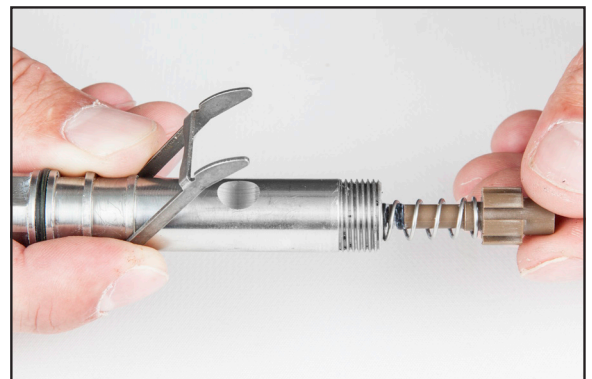



Kirby Morgan Dive Systems, Inc.®

1430 Jason Way Santa Maria, California 93455

Phone: 805/928-7772 Fax: 805/928-0342

www.KirbyMorgan.com email: kmdsi@KirbyMorgan.com

5. Lightly lubricate the ends of the Transfer Pin and install into the end of the Balance Spacer. Thread the Flex Knob Assembly onto the end of the Main Tube (closest to the lever arms) until it just stops. Hand tighten the Flex Knob Assembly and then back the Flex Knob out three turns.

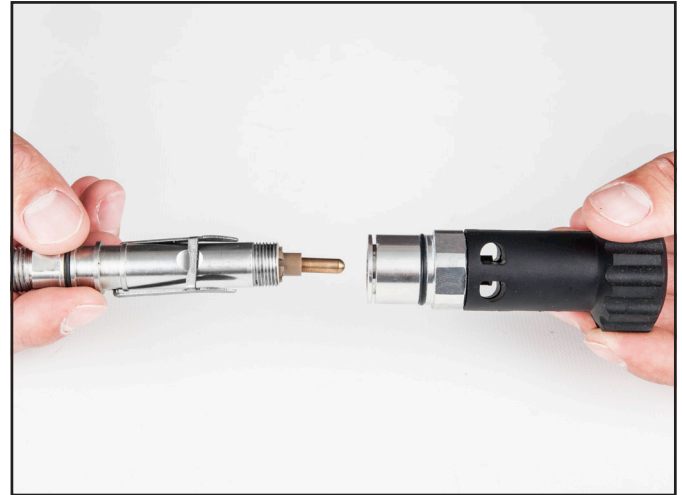
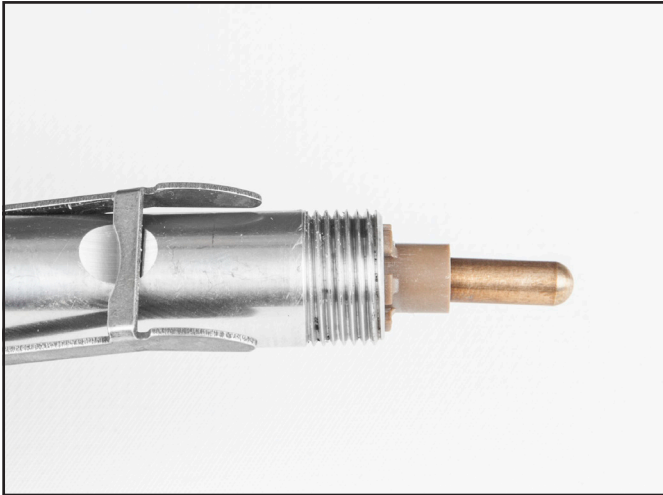

6. Install the Bearing Clip onto the outside of the Main Tube. Note that there is a locating pin on the clip that must engage the correct hole on the Main Tube. There are also small recesses on either side that the legs of the Lever Arm fit into. The clip is correctly positioned when it is in the position shown.

NOTE: For ease of installation, the spring tension on the Lever Arm may require the Lever Arm to be pulled more against the Spring to align the Balance Spacer.

Installing the Main Tube Assembly into Regulator Body

1. Ensure O-ring on Main Tube is in good condition and lubricated with Christo-Lube® or equivalent.



Kirby Morgan Dive Systems, Inc.®

1430 Jason Way Santa Maria, California 93455

Phone: 805/928-7772 Fax: 805/928-0342

www.KirbyMorgan.com email: kmcsi@KirbyMorgan.com



2. Lubricate the internal area of the regulator with approved lubricant where the Main Tube O-ring will insert. This is important to help prevent this O-ring from possibly getting cut when it is installed.

3. Install the Main Tube into the regulator body. Install the O-ring and the Bent Tube Adapter and tighten to the torque specifications from the correct Table (by model), see "Torque Specs" on page APNDX-19.



4. Tighten the Packing Nut at the Flex Knob with a $\frac{15}{16}$ " wrench to the torque specifications from the correct Table (by model), see "Torque Specs" on page APNDX-19. Turn in the Flex Knob until an audible click is heard then out three full turns. This is typically very close to the optimum position to check the adjustment.

5. Test the regulator for proper adjustment. Follow the procedures in "1.2.1 455 Balanced Demand Regulator Test for Correct Adjustment, Fully Assembled" on page 455BAL-1.

NOTE: If using a Superflow® 450 that was purchased before May 2015 the Packing Lock Clip P/N 540-531 will appear to have a different shape than the one included in this kit. They are the same part, use the same P/N, but have undergone a slight design change.

6. Install the Packing Lock Clip on the Main Tube, reinstall the Diaphragm and Cover Assembly. Tighten the Screws to the torque specifications from the correct table, see "Torque Specs" on page APNDX-19.



Kirby Morgan Dive Systems, Inc.®

1430 Jason Way Santa Maria, California 93455

Phone: 805/928-7772 Fax: 805/928-0342

www.KirbyMorgan.com email: kmdsi@KirbyMorgan.com



7. If necessary, adjust the regulator per "1.2.2 Adjusting the 455 Balanced Regulator" on page 455BAL-2.
8. Reinstall the Bent Tube assembly as per "1.3.3 Installation of the Bent Tube Assembly" on page BNT-5.



Kirby Morgan Dive Systems, Inc.
1430 Jason Way
Santa Maria, CA 93455, USA
Telephone (805) 928-7772, FAX (805) 928-0342
E-Mail: KMDSI@KirbyMorgan.com, Web Site: www.KirbyMorgan.com